



88136201



International Baccalaureate®
Baccalauréat International
Bachillerato Internacional

**DESIGN TECHNOLOGY
HIGHER LEVEL
PAPER 1**

Monday 18 November 2013 (afternoon)

1 hour

INSTRUCTIONS TO CANDIDATES

- Do not open this examination paper until instructed to do so.
- Answer all the questions.
- For each question, choose the answer you consider to be the best and indicate your choice on the answer sheet provided.
- The maximum mark for this examination paper is *[40 marks]*.

1. What is **not** true of an algorithm?
 - A. It is used in problem-solving.
 - B. It comprises a sequence of steps.
 - C. It helps to communicate complex processes.
 - D. It uses symbols to represent processes pictorially.

2. Which ideas-generating technique uses a two-dimensional matrix to explore design problems?
 - A. Attribute listing
 - B. Brainstorming
 - C. Constructive discontent
 - D. Morphological synthesis

3. What is the dominant form of thinking at the generation of ideas stage of the design cycle?

	Convergent thinking	Divergent thinking
A.	No	No
B.	No	Yes
C.	Yes	No
D.	Yes	Yes

4. **Figure 1** shows a Nokia ASHA 302 phone. It is designed for business users and features a QWERTY keyboard.

Figure 1: The Nokia ASHA 302 mobile phone with QWERTY keyboard



[Source: <http://www.nokia.com/gb-en/phones/phone/302/>. Used with permission.]

The QWERTY keyboard used on the Nokia ASHA 302 mobile phone is an example of

- A. dominant design.
 - B. imitative design.
 - C. robust design.
 - D. design family.
5. Which green design objective is most important for consideration in developing the design brief for a refrigerator in relation to “take back” legislation?
- A. The chosen materials
 - B. The user instructions
 - C. The packaging
 - D. Safety

6. In using data from a life cycle analysis for the redesign of a washing machine, which environmental consideration is likely to be the most important?
- A. Soil pollution and degradation
 - B. Noise
 - C. Water
 - D. Air contamination
7. What is the major advantage of organizing the result of a life cycle analysis into an environmental impact assessment matrix?
- A. It identifies the responsibilities of the designer.
 - B. It identifies design conflicts for resolution.
 - C. It identifies the most significant environmental impacts.
 - D. It identifies the priorities for redesign.

8. **Figure 2** shows the design of the European Union (EU) energy label for washing machines which is used in all 27 EU member states.

Figure 2: EU energy label for a washing machine

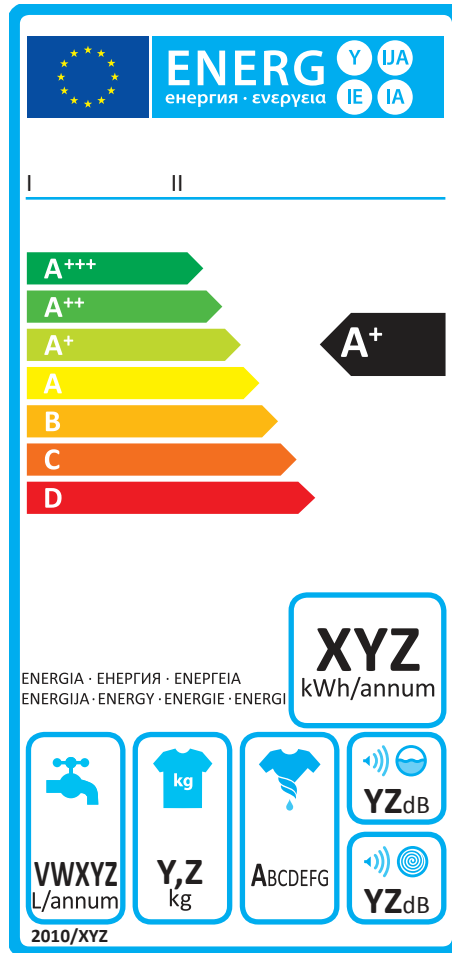

[Source: www.newenergylabel.com]

What are benefits of the design of the EU energy label for consumers?

- I. It overcomes potential language barriers in the EU marketplace.
 - II. It allows easy comparison with competitor products.
 - III. It identifies disposal options at the end-of-life.
- A. I and II only
 - B. I and III only
 - C. II and III only
 - D. I, II and III

9. A company rebuilds car engines for resale. This is an example of
- A. repair.
 - B. reconditioning.
 - C. reuse.
 - D. recycle.

10. **Figure 3** shows some green peppers on a market stall.

Figure 3: Green peppers on a market stall



[Source: © International Baccalaureate Organization 2014]

Which aesthetic characteristic is particularly important in selecting fruit and vegetables from a market stall?

- A. Appearance
- B. Taste
- C. Smell
- D. Texture

11. **Figure 4** shows a hardwood floor. Hardwood floors can be finished with a range of finishes, for example, lacquer.

Figure 4: A hardwood floor



[Source: www.howdens.com. Used with permission.]

What is a disadvantage of using lacquer for finishing the hardwood floor?

- A. Durability
- B. Low maintenance
- C. Prone to scratching
- D. Shiny appearance

12. A blacksmith makes a horseshoe by hammering iron which has been heated in a furnace (**Figure 5**). Once the final shape of the horseshoe is achieved it is cooled by dipping in a bath of cold water – a process called quench hardening.

Figure 5: Manufacturing a horseshoe



[Source: <http://www.cottamhorseshoes.com>. Used with permission]

Which combination of rate of cooling and grain size is achieved by quench hardening the hot iron?

	Rate of cooling	Grain size
A.	Rapid	Small
B.	Slow	Small
C.	Rapid	Large
D.	Slow	Large

13. What is a major disadvantage of using polyvinyl chloride (PVC) instead of metal for the manufacture of drainpipes?
- A. More expensive
 - B. PVC cannot be recycled as easily as other plastics
 - C. Difficult to manufacture
 - D. Moisture resistance
14. **Figure 6** shows a car windscreen (windshield) that has been damaged through impact.

Figure 6: A car windscreen damaged by impact



[Source: <http://commons.wikimedia.org/wiki/File:Windshield-spiderweb.jpg>]

What glass would have been used to manufacture the windscreen of the car?

- A. Soda glass
- B. Pyrex glass
- C. Toughened glass
- D. Laminated glass

15. What is **not** true of an end-of-pipe solution to cleaning up a manufacturing process?
- A. It is an incremental approach to clean technology.
 - B. It increases the complexity of a manufacturing process.
 - C. It identifies where waste and emissions come from in a manufacturing process.
 - D. It is consistent with sustainable development.
16. What increases after the break-even point as the volume of production increases?
- A. Unit cost of production
 - B. Profit
 - C. Fixed cost per unit
 - D. Variable cost per unit
17. What was a limitation of the use of water power at the start of the Industrial Revolution?
- A. Cost
 - B. Safety
 - C. Location
 - D. Low energy conversion
18. What is an advantage of using computer numerical control (CNC) machinery in an automated production system?
- A. Reduced waste
 - B. Increased capital costs
 - C. Reduced overheads
 - D. Increased productivity

19. **Figure 7** shows a child’s shape sorting toy.

Figure 7: Child’s shape sorter

Figure 7 removed for copyright reasons
Go to this link: http://www.battatco.com/products/battat/battat_pg/products_battat.html#!prettyPhoto/12/

What would have been a major consideration in the design specification for the shape sorter shown in **Figure 7**?

	Texture	Colour
A.	No	No
B.	No	Yes
C.	Yes	No
D.	Yes	Yes

20. Which of the following processes have been made easier by the introduction of automation?

	Quality control	Quality assurance
A.	No	No
B.	No	Yes
C.	Yes	No
D.	Yes	Yes

21. Which type of power results in the production of carbon dioxide?

- A. Steam power
- B. Nuclear power
- C. Hydroelectric power
- D. Solar power

22. Why is the development of large-scale wind energy plants considered problematic in some countries?

- A. Pollution
- B. Running costs
- C. Contribution to global warming
- D. Waste disposal

23. **Figure 8** shows a solar brick which is the shape and size of a floor tile. It can be used to light paths or provide light around a swimming pool (**Figure 9**).

Figure 8: A solar brick



Figure 9: Solar bricks providing lighting around a swimming pool

Figure 9 removed for copyright reasons

[Source: www.thesolarcentre.co.uk. Used with permission.]

Why is there a need for the solar brick to incorporate a battery?

- A. Lower running costs
- B. To store electricity for use at night
- C. To reduce the amount of electricity used
- D. Increase light intensity from the solar brick

24. **Figure 10** shows a stress-strain graph for a material. Which point indicates the ultimate tensile strength of the material?

Figure 10: A stress-strain graph for a material

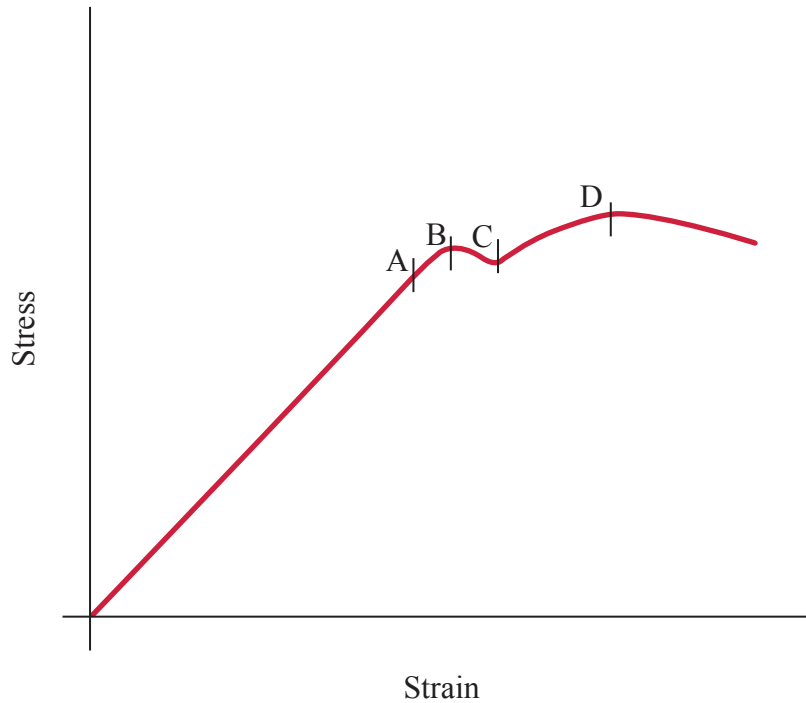

25. Which formula is used to calculate stress?

- A. $\frac{\text{change in length}}{\text{original length}}$
- B. $\frac{\text{load}}{\text{deflection}}$
- C. $\frac{\text{force}}{\text{area}}$
- D. $\frac{\text{design load}}{\text{normal maximum load}}$

26. **Figure 11** shows a man cleaning the windows of an office block using a brush with a telescopic handle. When fully extended to reach the higher windows the brush is much more difficult to control.

Figure 11: A man cleaning windows using a telescopic brush



[Source: © International Baccalaureate Organization 2014]

Which characteristic of the brush makes it much more difficult to control when fully extended?

- A. Strength of the material
- B. Stiffness of the material
- C. Strength of the structure
- D. Stiffness of the structure

27. **Figure 12** shows a metalworking lathe made by the Putnam Machine Company which is on display in the Hagley Museum in Wilmington in the United States. The lathe is driven by a flat belt drive system.

Figure 12: A belt drive system

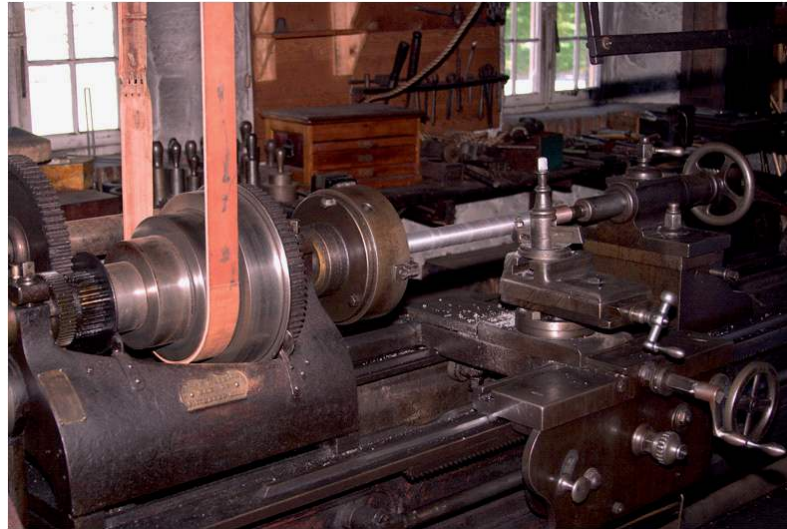

[Source: <http://en.wikipedia.org/wiki/File:PutnamLatheHagley02.jpg>]

What best describes a second class lever?

- A. effort, load, fulcrum
- B. effort, fulcrum, load
- C. load, effort, fulcrum
- D. fulcrum, load, effort

28. **Figure 13** shows the adjustable seat in a passport photo-booth in a retail store. The seat incorporates a screw thread and can be adjusted so that the head of the person is in the centre of the photo (Figure 14).

Figure 13: A passport photo-booth



[Source: © International Baccalaureate Organization 2014]

Figure 14: Adjusting the seat in a passport photo-booth



[Source: © International Baccalaureate Organization 2014]

What is the advantage of using a screw thread in this application?

- I. Once the seat height is set, high friction prevents slippage
 - II. Allows for fine adjustment of the seat height
 - III. Allows the seat to be adjusted to pre-set heights
- A. I and II only
 - B. I and III only
 - C. II and III only
 - D. I, II and III

29. The mechanism operating a foot-operated trash/rubbish bin is a very simple linkage. It consists of a series of fixed and moving pivots and levers. As a foot presses on the pedal the linkage (X) to which it is attached moves downwards forcing the next linkage (Y) to move upwards and to open the lid (Figure 15). Which element of the foot-operated trash/rubbish bin mechanism is an example of a fixed pivot?

Figure 15: The mechanism in a foot-operated trash/rubbish bin

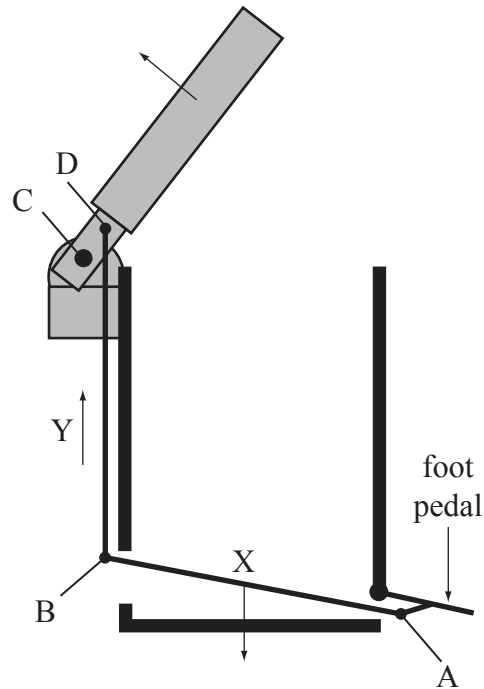

30. What is a disadvantage of friction welding two pieces of metal rod?
- A. The material has to be cleaned carefully before being welded.
 - B. Both pieces of metal are shortened.
 - C. It is suitable for joining different materials.
 - D. It results in a strong joint.
31. Which process is suitable for the creation of hollow-sectioned components, for example, rowing oars?
- A. Vacuum bagging
 - B. Lamination
 - C. Filament winding
 - D. Spray-up

32. What is an advantage of high-pressure die casting?
- A. High tooling costs
 - B. Wide range of possible shapes
 - C. Can only be used with high fluidity metals
 - D. Cost-effective for low volume production
33. What is an advantage of the Bellagio principles for sustainable development?
- A. Provides a methodology to enforce compliance with sustainable development
 - B. Identifies global legislation for sustainable development
 - C. Sets specific targets for sustainable development goals
 - D. Provides a framework to assess progress towards sustainable development
34. How does the use of grey water contribute to sustainable building design?
- A. Reduces clean water consumption
 - B. Reduces water consumption
 - C. Monitors water consumption
 - D. Replaces clean water consumption for dishwashing
35. Which factor used in determining the heat flow through a material is a constant?
- A. Area
 - B. Thickness
 - C. Temperature difference
 - D. Thermal conductivity

Questions 36–40 relate to the following case study. Please read the case study carefully and answer the questions.

The original red Associated Equipment Company (AEC) Routemaster bus developed in 1954 became an iconic feature of London’s streets (**Figure 16**). The bus is driven by an electric motor powered by a battery pack recharged by a diesel engine that only runs when the battery needs charging so the redesigned bus produces less pollution and has better fuel consumption. A prototype of a new Routemaster bus (**Figure 17**) modelled on the original but with enhanced performance was used in a field trial on the streets of London in February 2012. The windows allow more daylight into the bus and give the driver better kerbside views. There are two staircases and three doors – one at the front, a ramped centre door and an open platform at the rear to allow passengers to “hop-on hop-off” (**Figure 18**).

Figure 16: The original AEC Routemaster bus **Figure 17: The new Routemaster bus (front view)**



[Source: http://en.wikipedia.org/wiki/File:Heritage_Routemaster.jpg]



[Source: ©Antonio Curcetti. Used with permission.]

Figure 18: The new Routemaster bus



[Source: [http://commons.wikimedia.org/wiki/File:Metroline_bus_LT15_\(LTZ_1015\),_route_24,_22_June_2013.jpg](http://commons.wikimedia.org/wiki/File:Metroline_bus_LT15_(LTZ_1015),_route_24,_22_June_2013.jpg)]

36. Which feature of the design of the new Routemaster bus is mainly the result of radical thinking?
- A. The shape
 - B. The windows
 - C. The engine
 - D. The colour
37. Which aspects of the design of the new Routemaster bus will contribute to a reduction in the time taken for passengers to get on and off the bus compared to the original design?
- I. The extra doors
 - II. The extra staircase
 - III. The open platform
- A. I and II only
 - B. I and III only
 - C. II and III only
 - D. I, II and III
38. Which stakeholder is likely to provide the most feedback to the manufacturer from the field trial to evaluate the prototype of the new Routemaster bus?
- A. Bus driver
 - B. Client
 - C. Passenger
 - D. Designer

39. What would be the most useful criterion on which to segment the target market for the prototype of the new Routemaster bus?
- A. Geographical location
 - B. Age
 - C. Income
 - D. Lifestyle
40. Which combination of sustainability is the new Routemaster bus an example of?
- I. Economic sustainability
 - II. Environmental sustainability
 - III. Social sustainability
- A. I and II only
 - B. I and III only
 - C. II and III only
 - D. I, II and III
-